



TECHNICAL DATA

4CX3500A VHF RADIAL BEAM POWER TETRODE

The EIMAC 4CX3500A is a compact ceramic/metal radial beam power tetrode intended for use in VHF power amplifier applications. It features a type of internal mechanical structure which results in high rf operating efficiency. Low rf losses in this structure permit operation at full ratings to 220 MHz.

The 4CX3500A has a gain of over 18 dB in FM broadcast service, and is also recommended for rf linear power amplifier service and for VHF-TV linear amplifier service. The anode is rated for 3500 watts of dissipation with forced-air cooling.



GENERAL CHARACTERISTICS ¹

ELECTRICAL

Filament: Thoriated Tungsten Mesh

Voltage	5.0 ± 0.25 V
Current, at 5.0 volts	90 A

Amplification Factor, average

Grid to Screen	4.5
--------------------------	-----

Direct Interelectrode Capacitances (cathode grounded)²

Cin	111 pF
Cout	12 pF
Cgp	0.5 pF

Direct Interelectrode Capacitances (grids grounded)²

Cin	58.5 pF
Cout	10 pF
Cpk	0.4 pF

Maximum Frequency for Full Ratings (CW)	220 MHz
---------------------------------------------------	---------

1. Characteristics and operating values are based on performance tests. These figures may change without notice as the result of additional data or product refinement. Varian EIMAC should be consulted before using this information for final equipment design.
2. Capacitance values are for a cold tube as measured in a special shielded fixture in accordance with Electronic Industries Association Standard RS-191.

MECHANICAL

Maximum Overall Dimensions:

Length	7.25 in; 18.42 cm
Diameter	4.94 in; 12.55 cm

Net Weight (approximate) 5.5 Lbs; 2.5 kg

Operating Position Axis Vertical, Base Up or Down

Cooling Forced Air

Maximum Operating Temperature, Ceramic/Metal Seals & Anode Core 250 Deg.C

Base Special, Coaxial

Recommended Air-System Socket HF: EIMAC SK-340

VHF: EIMAC SK-350

Recommended Air-System Chimney HF: EIMAC SK-306

VHF: EIMAC SK-356

RADIO FREQUENCY POWER AMPLIFIER
TYPICAL OPERATION (frequencies to 30 MHz)

 Class C Telegraphy or FM
 (Key-down Conditions)

Plate Voltage	5.0	5.0	kVdc
Screen Voltage	500	500	
Grid Voltage	-200	-250	Vdc
Plate Current	1.32	0.80	Adc
Screen Current *	75	43	mAdc
Grid Current *	59	21	mAdc
Peak rf Grid Voltage *	335	290	v
Calculated Driving Power	25	7	W
Plate Dissipation *	1320	640	W
Plate Output Power *	5280	3360	W
Load Impedance	1700	2700	Ohms

ABSOLUTE MAXIMUM CONDITIONS

DC PLATE VOLTAGE	6000	VOLTS
DC SCREEN VOLTAGE	1500	VOLTS
DC GRID VOLTAGE	-500	VOLTS
DC PLATE CURRENT	2.0	AMPERES
PLATE DISSIPATION	3500	WATTS
SCREEN DISSIPATION	165	WATTS
GRID DISSIPATION	50	WATTS

* Approximate value

RADIO FREQUENCY POWER AMPLIFIER
FM BROADCAST SERVICE
MEASURED DATA AT 100.5 MHZ
ABSOLUTE MAXIMUM RATINGS

DC PLATE VOLTAGE	6000	VOLTS
DC SCREEN VOLTAGE	1500	VOLTS
DC GRID VOLTAGE	-500	VOLTS
DC PLATE CURRENT	2.0	AMPERES
PLATE DISSIPATION	3500	WATTS
SCREEN DISSIPATION	165	WATTS
GRID DISSIPATION	50	WATTS

Plate Voltage	4000	4300	Vdc
Plate Current	1.5	1.9	Adc
Screen Voltage	500	700	Vdc
Screen Current *	140	123	mAdc
Grid Voltage	-300	-400	Vdc
Grid Current *	84	63	mAdc
Useful Power Out * #	3838	5531	W
Efficiency *	64	68	%
Driving Power *	56	66	W
Power Gain *	18.4	19.2	dB

* Approximate; will vary from tube to tube

Delivered to the load

TYPICAL OPERATION values are obtained by measurement or by calculation from published characteristic curves. To obtain the specified plate current at the specified bias, screen, and plate voltages, adjustment of the rf grid voltage is assumed. If this procedure is followed, there will be little variation in output power when the tube is replaced, even though there may be some variation in grid and screen currents. The grid and screen currents which occur when the desired plate current is obtained are incidental and vary from tube to tube. These current variations cause no performance degradation providing the circuit maintains the correct voltage in the presence of the current variations. If grid bias is obtained principally by means of a grid resistor, the resistor must be adjusted to produce the required bias voltage when the correct rf grid voltage is applied.

APPLICATION

MECHANICAL

MOUNTING - The 4CX3500A must be mounted with its axis vertical, base up or down at the convenience of the circuit designer.

AIR-SYSTEM SOCKET & CHIMNEY - The EIMAC sockets type SK-340 and SK-350 are designed especially for the concentric base terminals of the 4CX3500A. The SK-340 is intended for use at HF, while the SK-350 is recommended for VHF applications. The SK-306 chimney should be used with the SK340 socket for the lower frequencies, while the SK-356 chimney is intended for use with the SK-350 socket. Use of the recommended air flow rates through either socket will provide effective forced-air cooling of the tube. Air forced into the bottom of the socket passes over the tube terminals and through the chimney and into the anode cooling fins.

COOLING - At full rated anode dissipation, at sea level and with cooling air at 50 Deg.C maximum, for frequencies below 110 MHz, and with the tube mounted in either an SK-340 or SK-350 socket with a chimney in place, a minimum of 241 CFM of air must be passed through the socket and the tube anode cooling fins. Air flow should be in the base-to-anode direction. The pressure drop across the tube/ socket/chimney combination with this air flow rate will be approximately 1.87 inches of water.

The blower selected in a given application must be capable of supplying the desired air flow at a back pressure equal to that shown, plus any drop encountered in ducts and filters.

Air flow must be applied before or simultaneously with the application of power, including the tube filament, and may be removed simultaneously with filament voltage. An air interlock system should be incorporated in the design to automatically remove all voltages from the tube in case of even a partial failure of the tube cooling air.

It is considered good engineering practice to supply more than the minimum required cooling air, to allow for variables such as dirty air filters, rf seal heating, and the fact that the anode cooling fins may not be clean if the tube has been in service for some time.

ELECTRICAL

ABSOLUTE MAXIMUM RATINGS - The values shown for each type of service are based on the "absolute system" and are not to be exceeded under any service conditions. These ratings are limiting values outside which the serviceability of the tube may be impaired. In order not to exceed absolute ratings the equipment designer has the responsibility of determining an average design value for each rating below the absolute value of that rating by a safety factor so that the absolute values will never be exceeded under any usual conditions of supply voltage variation in the equipment itself. It does not necessarily follow that combinations of absolute maximum ratings can be attained simultaneously.

FILAMENT OPERATION - At rated (nominal) filament voltage the peak emission capability of the tube is many times that needed for communication service. A reduction in filament voltage will lower the filament temperature, which will substantially increase life expectancy. The correct value of filament voltage should be determined for the particular application. It is recommended the tube be operated at full nominal voltage for an initial stabilization period of 100 to 200 hours before any action is taken to operate at reduced voltage. The voltage should gradually be reduced until there is a slight degradation in performance (such as power output or distortion). The filament voltage should then be increased a few tenths of a volt above the value where performance degradation was noted. The operating point should be rechecked after 24 hours. Filament voltage should be closely regulated when voltage is to be reduced below nominal in this manner, to avoid any adverse influence by normal line voltage variations.

Filament voltage should be measured at the tube base or socket, using an accurate rms-responding meter. Periodically the procedure outlined above for reduction of voltage should be repeated, with voltage reset as required, to assure best life.

GRID OPERATION - The maximum control grid dissipation is 50 watts, determined approximately by the product of the dc grid current and the peak positive grid voltage.

SCREEN OPERATION - The maximum screen grid dissipation is 165 watts. With no ac applied to the screen grid, dissipation is simply the product of dc screen voltage and the dc screen current. With screen modulation, dissipation is dependent on rms screen voltage and rms screen current. Plate voltage, plate loading, or bias voltage must never be removed while filament and screen voltages are present, since screen dissipation ratings will be exceeded. A protective spark-gap device should be connected between the screen grid and the cathode to guard against excessive voltage.

SCREEN CURRENT - The screen current may reverse under certain conditions and produce negative indications on the screen current meter. This is a normal characteristic of most tetrodes. The screen power supply should be designed with this characteristic in mind, so that the correct operating voltage will be maintained on the screen under all conditions. A current path from the screen to cathode must be provided by a bleeder resistor or a shunt regulator connected between screen and cathode and arranged to pass approximately 10% of the average screen current per connected tube. A series regulated power supply can be used only when an adequate bleeder resistor is provided.

FAULT PROTECTION - In addition to the normal plate over-current interlock, screen current interlock, and air-flow interlock, the tube must be protected from internal damage caused by an internal plate arc which may occur at high plate voltage. A protective resistance should always be connected in series with each tube anode, to absorb power supply stored energy if an internal arc should occur. EIMAC's Application Bulletin #17 titled **FAULT PROTECTION** contains considerable detail, and is available on request.

HIGH VOLTAGE - Normal operating voltages used with this tube are deadly, and the equipment must be designed properly and operating precautions must be followed. Design all equipment so that no one can come in contact with high voltages. All equipment must include safety enclosures for high-voltage circuits and terminals, with interlock switches to open primary circuits of the power supply and to discharge high-voltage capacitors

whenever access doors are opened. Interlock switches must not be bypassed or "cheated" to allow operation with access doors open. Always remember that **HIGH VOLTAGE CAN KILL**.

RADIO-FREQUENCY RADIATION - Avoid exposure to strong rf fields even at relatively low frequency. Absorption of rf energy by human tissue is dependent on frequency. Under 300 MHz most of the energy will pass completely through the human body with little attenuation or heating effect. Public health agencies are concerned with the hazard even at these frequencies. OSHA (Occupational Safety and Health Administration) recommends that prolonged exposure to rf radiation should be limited to 10 milliwatts per square centimeter.

INTERELECTRODE CAPACITANCE - The actual internal interelectrode capacitance of a tube is influenced by many variables in most applications, such as stray capacitance to the chassis, capacitance added by the socket used, stray capacitance between tube terminals, and wiring effects. To control the actual capacitance values within the tube, as the key component involved, the industry and Military Services use a standard test procedure as described in Electronic Industries Association Standard RS-191. This requires the use of specially constructed test fixtures which effectively shield all external tube leads from each other and eliminates any capacitance reading to "ground". The test is performed on a cold tube. Other factors being equal, controlling internal tube capacitance in this way normally assures good interchangeability of tubes over a period of time. The capacitance values shown here are taken in accordance with Standard RS-191. The equipment designer is therefore cautioned to make allowance for the actual capacitance values which will exist in any normal application. Measurements should be taken with the socket and mounting which represent approximate final layout if capacitance values are highly significant in the design.

SPECIAL APPLICATIONS - When it is desired to operate this tube under conditions widely different from those listed here, write to Varian EIMAC; attn: Applications Engineering; 301 Industrial Way; San Carlos, CA 94070 U.S.A.

OPERATING HAZARDS

PROPER USE AND SAFE OPERATING PRACTICES WITH RESPECT TO POWER TUBES ARE THE RESPONSIBILITY OF EQUIPMENT MANUFACTURERS AND USERS OF SUCH TUBES. ALL PERSONS WHO WORK WITH OR ARE EXPOSED TO POWER TUBES OR EQUIPMENT WHICH UTILIZES SUCH TUBES MUST TAKE PRECAUTIONS TO PROTECT THEMSELVES AGAINST POSSIBLE SERIOUS BODILY INJURY. DO NOT BE CARELESS AROUND SUCH PRODUCTS.

The operation of this tube may involve the following hazards, any one of which, in the absence of safe operating practices and precautions, could result in serious harm to personnel:

- a. HIGH VOLTAGE - Normal operating voltages can be deadly. Always remember that HIGH VOLTAGE CAN KILL. and can cause serious bodily and eye injuries. CARDIAC PACEMAKERS MAY BE EFFECTED.
- b. RF RADIATION - Exposure to strong rf fields should be avoided, even at relatively low frequencies. The dangers of rf radiation are more severe at UHF and microwave frequencies
- c. HOT SURFACES - Surfaces of air-cooled radiators and other parts of tubes can reach temperatures of several hundred Degrees C and cause serious burns if touched for several minutes after all power is removed.

Please review the detailed operating hazards sheet enclosed with each tube, or request a copy from: Varian EIMAC, Power Grid Tube Division, 301 Industrial Way, San Carlos CA 94070.



4CX3500A

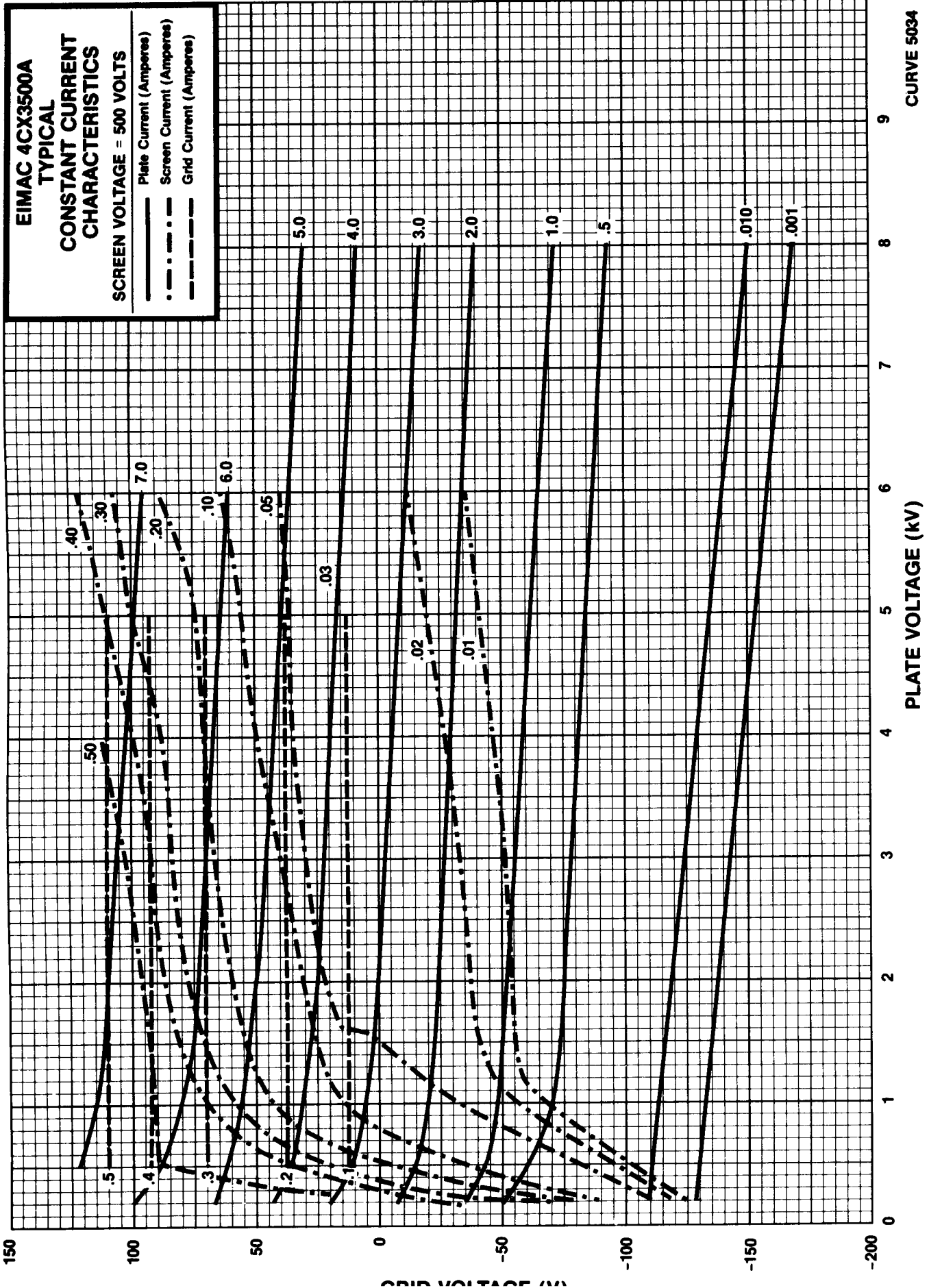

CURVE 5034



DIM	INCHES			MILLIMETERS		
	MIN	MAX	REF	MIN	MAX	REF
A	4.812	4.938		122.22	125.43	
B	.855	.895		21.72	22.73	
C	.600	.760		15.24	19.30	
D	1.896	1.936		48.16	49.17	
E	3.133	3.173		79.58	80.59	
F	3.792	3.832		96.32	97.33	
G	3.980	4.020		101.09	102.11	
H	.188			4.78		
J	.188			4.78		
K	.188			4.78		
M	3.474	3.848		88.11	94.28	
N	1.369	1.733		35.30	42.48	
P	6.831	7.181		100.81	176.83	
S	2.369	2.738		67.80	68.98	
T	.375			9.53		

NOTES:

1. REF DIMENSIONS ARE FOR INFO ONLY & ARE NOT REQUIRED FOR INSPECTION PURPOSES.
2. DIMENSIONS IN [] ARE MILLIMETERS.
3. (*) CONTACT SURFACE.
4. OPTIMUM FILAMENT & GRID CONNECTOR HEIGHTS FOR SOCKET DESIGN PURPOSES.

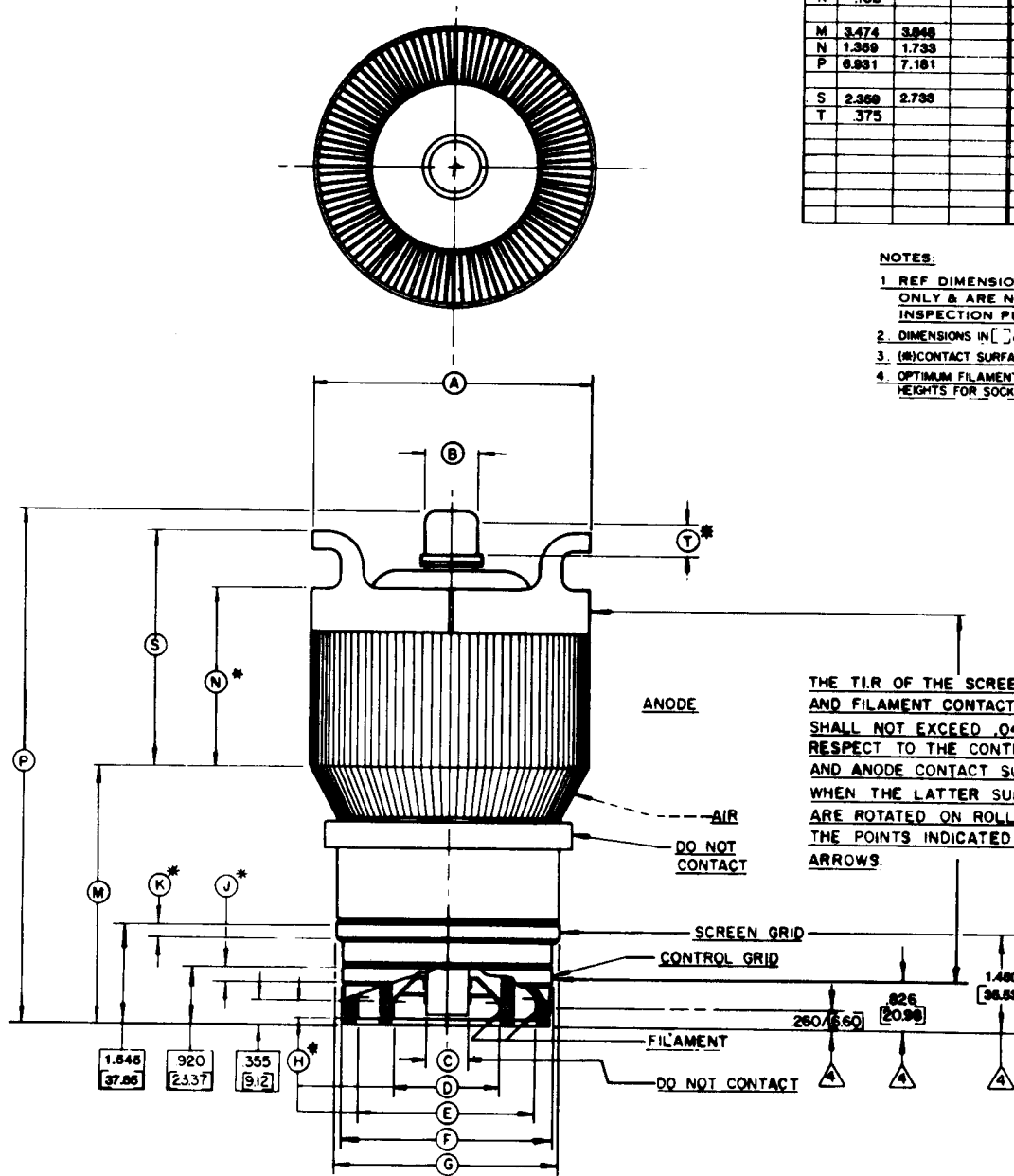

THE TIR OF THE SCREEN GRID AND FILAMENT CONTACT SURFACES SHALL NOT EXCEED .040 WITH RESPECT TO THE CONTROL GRID AND ANODE CONTACT SURFACE WHEN THE LATTER SURFACES ARE ROTATED ON ROLLERS AT THE POINTS INDICATED BY THE ARROWS.